

10/100/1000 Base TX to 1000 Base FX

Overview

This product supports IEEE802.3 10 Base-T standard/IEEE 802.3u 100Base-TX/FX standard/IEEE 802.3z 1000Base-TX/FX standard, as well as full duplex and half duplex mode.

Installation

1. Interface

RJ-45 interface

The transmission media adopts CAT5 twisted-pair with typical length of 100 meter. It features the function of automatically identifying the through line and cross wire

Fiber interface

SC/ST fiber interface is of duplex mode type, including two interfaces, namely TX and RX. When the two sets of optical transceiver are interfaced or connected to switch with fiber interface, the fiber is in cross connection, namely "TX-RX", "RX-TX" (direct butting for single optical fiber).

2. Connection

The network device (work station, hub or switch) with RJ-45 interface is connected to RJ-45 jack of optical transceiver through twisted-pair. And the multi/single mode fiber is connected to SC/ST fiber interface of the optical transceiver. Then switch on. The corresponding LED is on for correct connection. (See the table below for the LED indicator lamp)

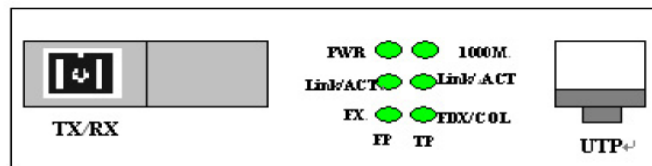

Table 1 : Front panel for single fiber media converter

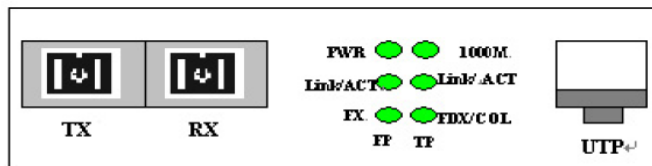

Table 2 : Front panel for dual fiber media converter

Explanation for LED indicator lamp

LED indicator lamps serve as device monitoring and trouble display. The following is the explanation for each LED indicator lamp.

LED	function	status	Describing
PWR	Power LED	ON	Power is ON.
		OFF	Power is Fail.
FX	Fiber port signal detect LED	ON	Laser is receiving.
		OFF	No laser input.
FX-LINK/ACT	Fiber port link/action status LED	ON	Fiber link is ok.
		Blink	Data is been received or transmitted
		OFF	Fiber link is fail.
1000M	UTP port speed LED	ON	1000M speed
		OFF	100M speed
TX-LINK/ACT	UTP port link/action status LED	ON	Link is ok.
		Blink	Data is been received or transmitted
		OFF	Link is fail.
FDX/COL	UTP port duplex LED	ON	Full duplex
		OFF	Half duplex

Main features

- In conformity to IEEE 802.3 10 Base-T standard.
In conformity to IEEE 802.3u 100 Base-TX/FX standard.
In conformity to IEEE 802.3z 1000 Base-TX/FX standard.
- Max. 2M buffer memory built in chip.
- Back pressure flow control for full duplex
IEEE802.3 X and half duplex.
- Automatic identification of MDI/MDI-X cross line.
- High-performance 1.4Gbps memory bandwidth.
- In conformity to safety code of FCC and 15 CLASS B and CE MARK.

Technical parameters:

- Standard Protocol: IEEE802.3 10 Base-T standard
IEEE 802.3u 100Base-TX/FX standard
IEEE 802.3z 1000Base-TX/FX standard
- Connector: one UTP RJ-45 connector, one SC/ST connector
- Operation mode: full duplex mode or half duplex mode
- Power supply parameter: outside: 5V DC 2A
built-in: 110-265V AC 48VDC
- Environmental temperature: 0°C-60 °C
- Relative humidity: 5%-90%
- TP cable: Cat5 UTP cable
- Transfer fiber:
multi-mode: 50/125, 62.5/125 or 100/140µm
single mode: 8.3/125, 8.7/125, 9/125 or 10/125µm

10 Dimensions:

External power supply: 26mmx 70mm x 95mm

Internal power supply: 30mm x 110mm x 140mm

Cautions:

1. This product is suitable for indoor application.
2. Put on the dust cover of fiber interface when not used.
3. It is forbidden to stare at the TX fiber-transfer end with naked eyes.
4. Single optical fiber transceiver must be used in pair (See the attachment description in delivery).

Trouble shooting:

1. Device is not matched. Please select the corresponding network device according to the transfer rate of the product (10Mbps or 100Mbps) when connected to other network devices (network card, hub, switch).
2. Line loss is excessive during the fiber wiring. Excessive loss in connector plug-in and fiber soldering welding, and excessive intermediate nodes may cause excessive loss rate or abnormal operation.

PART NUMBER CONFIGURATION

Please use the below part number description to obtain the exact part number as required.

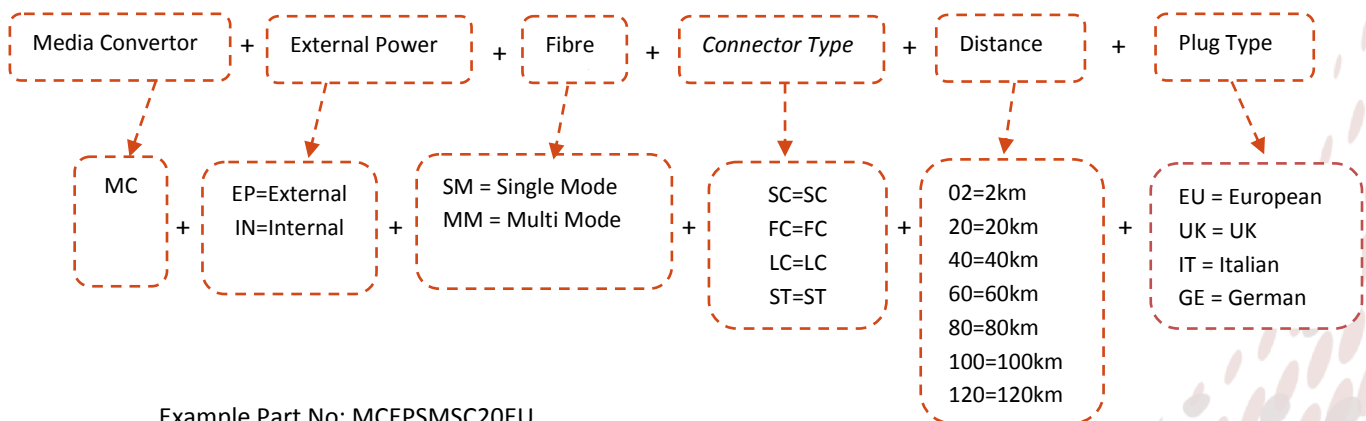

Example Part No: MCEPSMSC20EU

Please contact Linxcom at sales@linx-com.com for any queries. Thank you.



Meets Standards By